

YORK[®]

Heating and Air Conditioning

TECHNICAL GUIDE

SPLIT-SYSTEM AIR CONDITIONERS

14.5 SEER – R-410A

MODELS:
YCJF24 THRU 60
(2 THRU 5 NOMINAL TONS, 1 PHASE)



Due to continuous product improvement, specifications are subject to change without notice.

Visit us on the web at www.york.com

Additional rating information can be found at www.ahrdirectory.org

DESCRIPTION

The 14.5 SEER Series condensing unit is the outdoor part of a versatile system of air conditioning. It is designed to be custom-matched with one of UPG's complete line of evaporator sections, with each serving a specific function. Matching Air Handlers are available for upflow, downflow, or horizontal applications to provide a complete system. Electric Heaters are available, if required. Add-on coils are available for use with upflow, downflow, or horizontal furnaces and air handlers.

WARRANTY

Single Phase Units:

5-year limited parts warranty.

10-year limited compressor warranty.

FEATURES

- **QUALITY CONDENSER COILS** - The coil is constructed of aluminum microchannel tubing and enhanced aluminum fins for increased efficiency and corrosion protection.
- **PROTECTED COMPRESSOR** - The compressor is internally protected against high pressure and temperature and externally by a factory installed high pressure switch. This protects the compressor if undesirable operating conditions occur. A liquid line filter-drier further protects the compressor.
- **DURABLE FINISH** - The cabinet is made of pre-painted steel. The pre-treated galvanized steel provides a better paint to steel bond, which resists corrosion and rust creep. Special primer formulas and matted-textured finish insure less fading when exposed to sunlight.
- **LOWER INSTALLED COST** - Installation time and costs are reduced by easy power and control wiring connections. Available in sweat connect models only. The unit contains enough refrigerant for matching indoor coils and 15 feet of interconnecting piping. The small base dimension means less space is required on the ground or roof.
- **TOP DISCHARGE** - The warm air from the top mounted fan is blown up away from the structure and any landscaping. This allows compact location on multi-unit applications.
- **LOW OPERATING SOUND LEVEL** - The upward air flow carries the normal operating noise away from the living area. The rigid top panel effectively isolates any motor sound. Isolated compressor mounts minimize compressor operating sounds. Additional sound attenuation is provided by a swept-wing fan blade and compressor blanket.
- **LOW MAINTENANCE** - Long life permanently lubricated motor-bearings need no annual servicing.
- **EASY SERVICE ACCESS** - Fully exposed refrigerant connections, and a single panel covering the electrical controls make for easy servicing of the unit.
- **SECURED SERVICE VALVES** - Secured re-usable service valves are provided on both the liquid and vapor sweat connections for ease of evacuating and charging.
- **U.L. and C.U.L. listed** - approved for outdoor application.

Certified in accordance with the Unitary Small Equipment certification program, which is based on ARI Standard 210/240.

Physical and Electrical Data

MODEL	YCJF24 S41S1	YCJF30 S41S1	YCJF36 S41S1	YCJF42 S41S1	YCJF48 S41S1	YCJF60 S41S1	
Unit Supply Voltage	208-230V, 1 ϕ , 60Hz						
Normal Voltage Range ¹	187 to 252						
Minimum Circuit Ampacity	16.8	18.4	19.1	23.9	27.9	35.9	
Max. Overcurrent Device Amps ²	25	30	30	40	45	60	
Min. Overcurrent Device Amps ³	20	20	20	25	30	40	
Compressor Type	Scroll	Scroll	Scroll	Scroll	Scroll	Scroll	
Compressor Amps	Rated Load	12.8	14.1	14.1	17.9	21.1	27.5
	Locked Rotor	58	73	77	112	115	135
Crankcase Heater	No	No	No	No	No	No	
Fan Motor Amps	Rated Load	.8	.8	1.5	1.5	1.5	1.5
	Fan Diameter Inches	22	22	22	24	24	24
Fan Motor	Rated HP	1/8	1/8	1/4	1/4	1/4	1/4
	Nominal RPM	1075	1075	850	850	850	850
	Nominal CFM	2750	2800	3200	3600	3600	3700
Coil	Face Area Sq. Ft.	13.1	17.4	17.4	20.0	21.4	24.0
	Rows Deep	1	1	1	1	1	1
	Fin / Inches	23	23	23	23	23	23
Liquid Line Set OD (Field Installed)	3/8	3/8	3/8	3/8	3/8	3/8	
Vapor Line Set OD (Field Installed)	3/4	3/4	3/4	7/8	7/8	1 1/8	
Unit Charge (Lbs. - Oz.) ⁴	3 - 2	3 - 7	3 - 10	4 - 4	4 - 9	5 - 9	
Charge Per Foot, Oz.	0.62	0.62	0.62	0.67	0.67	0.75	
Operating Weight Lbs.	128	130	145	172	180	199	

1. Rated in accordance with ARI Standard 110, utilization range "A".
2. Dual element fuses or HACR circuit breaker. Maximum allowable overcurrent protection.
3. Dual element fuses or HACR circuit breaker. Minimum recommended overcurrent protection.
4. The Unit Charge is correct for the outdoor unit, matched indoor coil and 15 feet of refrigerant tubing. For tubing lengths other than 15 feet, add or subtract the amount of refrigerant, using the difference in length multiplied by the per foot value.

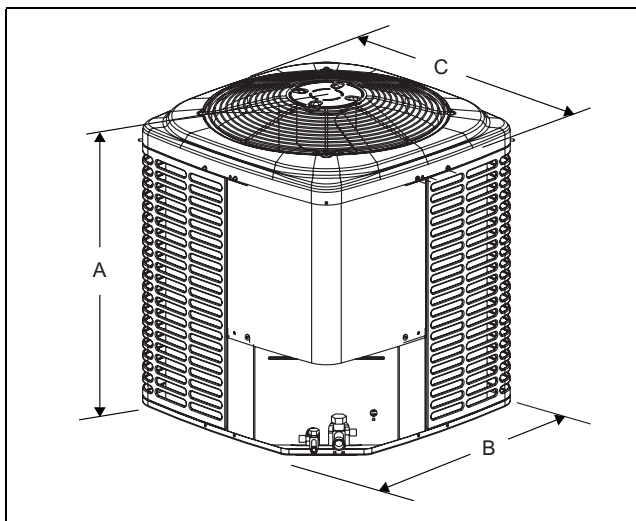

All dimensions are in inches. They are subject to change without notice. Certified dimensions will be provided upon request.

Unit Model	Dimensions (Inches)			Refrigerant Connection Service Valve Size	
	A ¹	B	C	Liquid	Vapor
24	28	29	29	3/8"	3/4"
30	36	29	29		
36	36	29	29		
42	34	33.6	33.6		7/8"
48	36	33.6	33.6		
60	40	33.6	33.6		

1. Including Fan Guard.
2. Adapter fitting required for 1-1/8" line set.

Additional R-410A Charge / Orifice Size for Various Matched Systems						
Outdoor Unit	YCJF24 S41S1	YCJF30 S41S1	YCJF36 S41S1	YCJF42 S41S1	YCJF48 S41S1	YCJF60 S41S1
Required Orifice or TXV ¹	1TVM902	1TVM903	1TVM903	1TVM903	1TVM905	1TVM906
Factory Charge, lbs-oz	3 - 2	3 - 7	3 - 10	4 - 4	4 - 9	5 - 9
Indoor Coil ^{2,3,4}	Additional Charge, Oz					
FC/MC/PC24A3X	5	-	-	-	-	-
FC/MC/PC24B3X	5	-	-	-	-	-
FC/MC/PC30A3X	12	2	-	-	-	-
FC/MC/PC30B3X	12	2	-	-	-	-
FC/MC/PC32A3X	16	10	-	-	-	-
FC/MC/PC35B3X	16	10	8	-	-	-
FC/MC/PC35C3X	16	10	8	-	-	-
FC/MC/PC36A3X	8	4	1	-	-	-
FC/MC/PC36B3X	8	4	1	-	-	-
FC/MC/PC36C3X	8	4	1	-	-	-
FC/MC/PC37A3X	24	19	15	-	-	-
FC/MC/PC43B3X	24	19	15	5	-	-
FC/MC/PC43C3X	24	19	15	5	-	-
FC/MC/PC48C3X	40	32	15	17	16	-
FC/MC/PC48D3X	40	32	27	17	16	-
FC/MC/PC60D3X	-	-	-	17	16	0
FC/MC62D3X	-	-	-	25	26	18
UC24A3X	8	-	-	-	-	-
UC24B3X	8	-	-	-	-	-
UC30A3X	8	4	-	-	-	-
UC30B3X	8	4	-	-	-	-
UC36A3X	-	-	-	-	-	-
UC36B3X	-	-	-	-	-	-
UC36C3X	-	-	-	-	-	-
UC42B3X	-	-	-	-	-	-
UC42C3X	-	-	-	-	-	-
UC48C3X	-	-	-	-	-	-
UC48D3X	-	-	-	-	-	-
UC60C3X	-	-	12	-	-	-
UC60D3X	-	-	12	-	-	-
HC18A3X	-	-	-	-	-	-
HC30A3X	10	-	-	-	-	-
HC36B3X	16	11	8	-	-	-
HC42C3X	25	19	15	6	-	-
HC60D3X	-	-	-	0	0	0
HD24*3X	16	-	-	-	-	-
HD36*3X	18	-	-	-	-	-
HD48*3X	51	42	36	24	25	-
HD60*3X	-	-	-	-	24	-
AHP18B3X	-	-	-	-	-	-
AHP24B3X	3	-	-	-	-	-
AHP30B3X	16	-	-	-	-	-
AHP36C3X	-	19	15	-	-	-
AHP42C3X	-	-	-	-	-	-
AHP/SHP60D3X	-	-	-	-	1	-
AV24B3X	3	-	-	-	-	-
AV36C3X	25	19	15	-	-	-
AV/SV48D3X	-	-	9	0	1	-
AV/SV60D3X	-	-	-	0	1	0

Additional R-410A Charge / Orifice Size for Various Matched Systems (Continued)

Outdoor Unit	YCJF24 S41S1	YCJF30 S41S1	YCJF36 S41S1	YCJF42 S41S1	YCJF48 S41S1	YCJF60 S41S1
Required Orifice or TXV ¹	1TVM902	1TVM903	1TVM903	1TVM903	1TVM905	1TVM906
Factory Charge, lbs-oz	3 - 2	3 - 7	3 - 10	4 - 4	4 - 9	5 - 9

Indoor Coil^{2,3,4}**Additional Charge, Oz**

For notes see Page 4.

F4FP024	See Caution below	0	–	–	–	–	–
F4FP030	See Caution below	3	0	–	–	–	–
F4FP036	See Caution below	–	8	5	–	–	–
F4FP040	See Caution below	–	12	8	–	–	–
F4FP042	See Caution below	–	–	8	0	–	–
F4FP045	See Caution below	–	–	9	2	–	–
F5FP048	See Caution below	–	–	20	10	11	–
F5FP060	See Caution below	–	–	20	10	11	–
F4FV060	See Caution below	–	–	9	10	1	–

FOOTNOTES:

1. Systems matched with furnace or air handlers not equipped with blower-off delays may require blower Time Delay Kit 2FD06700224.
2. PC coils cannot be used in downflow or horizontal applications. FC coils cannot be used in horizontal applications.
3. A TXV kit must be used with these coils to obtain system performance. Note: If a TXV is factory installed on the coil, it must be replaced with the listed TXV
4. Refer to Technical Guide for actual system performance for specified matches.

PROCEDURES:

1. Unit factory charge listed on the unit nameplate includes refrigerant for the condenser, the smallest evaporator and 15 feet of interconnecting line tubing.
2. Verify the TXV or orifice and additional charge required for specific evaporator coil in the system using the above table.
3. Add additional charge for the amount of interconnecting line tubing greater than 15 feet at the rate specified in Physical and Electrical Data Table.
4. For TXV match charge weight needs to be weighed in for specific coil match and lineset length.
5. Permanently mark the unit nameplate with the total system charge. Total System Charge = Base Charge (as shipped) + adder for evaporator + adder for line set.



If the F*FP Air Handler used has a with a factory installed R-22 TXV it **MUST BE CHANGED OUT** to a R-410A TXV or a orifice for proper operation.
If the TXV is not changed out system damage will occur.

COOLING CAPACITY - With Air Handler Coils

UNIT MODEL	AIR HANDLER		COIL MODEL ¹	COOLING				
	MODEL	W		RATED CFM	NET MBH		SEER	EER
					TOTAL	SENS.		
14.5 SEER AC WITH MA								
YCJF24S41S1	MA08B	17	FC/MC24B	800	24.8	17.3	14.35	12.15
	MA08B	17	FC/MC30B	800	24.8	17.3	14.35	12.15
	MA08B	17	FC/MC35B	800	25.0	17.6	14.50	12.25
	MA08B	17	FC/MC36B	800	25.0	17.6	14.40	12.25
	MA08B	17	FC/MC43B	800	25.2	18.0	14.60	12.35
YCJF30S41S1	MA12B	17	FC/MC30B	1000	28.8	20.6	14.00	12.00
	MA12B	17	FC/MC35B	1000	29.0	21.0	14.05	12.00
	MA12B	17	FC/MC36B	1000	29.0	21.0	14.00	12.00
	MA12B	17	FC/MC43B	1000	29.6	21.6	14.45	12.00
YCJF36S41S1	MA12B	17	FC/MC35B	1200	34.4	25.4	14.20	12.10
	MA12B	17	FC/MC36B	1200	34.2	25.0	14.00	12.00
	MA12B	17	FC/MC43B	1200	35.2	26.0	14.50	12.30
	MA14D	24	FC/MC48D	1200	35.6	26.4	14.65	12.35
YCJF42S41S1	MA16C	21	FC/MC43C	1400	40.5	30.4	14.10	12.10
	MA14D	24	FC/MC48D	1400	41.0	30.8	14.40	12.30
	MA16C	21	FC/MC48C	1400	41.0	30.8	14.40	12.30
	MA14D	24	FC/MC60D	1400	41.0	30.8	14.35	12.10
	MA16C	21	FC/MC60C	1400	41.0	30.8	14.35	12.10
	MA14D	24	FC/MC62D	1400	41.0	31.0	14.45	12.05
YCJF48S41S1	MA16C	21	FC/MC48C	1600	46.5	32.8	14.50	12.00
	MA20D	24	FC/MC48D	1600	46.5	32.8	14.50	12.00
	MA16C	21	FC/MC60C	1600	46.5	32.6	14.50	12.00
	MA20D	24	FC/MC60D	1600	46.5	32.6	14.50	12.00
	MA20D	24	FC/MC62D	1600	47.0	32.8	14.50	12.00
YCJF60S41S1	MA20D	24	FC/MC62D	1800	57.0	39.0	14.00	12.10
14.5 SEER AC WITH MV - VARIABLE SPEED								
YCJF24S41S1	MV12B	17	FC/MC24B	800	25.4	17.7	16.00	13.20
	MV12B	17	FC/MC30B	800	25.4	17.7	16.00	13.20
	MV12B	17	FC/MC35B	800	25.6	18.0	16.00	13.50
	MV16C	21	FC/MC35C	800	25.6	18.0	16.00	13.50
	MV12B	17	FC/MC36B	800	25.6	18.0	16.00	13.50
	MV16C	21	FC/MC36C	800	25.6	18.0	16.00	13.50
	MV12B	17	FC/MC43B	800	25.8	18.4	16.10	13.75
	MV16C	21	FC/MC43C	800	25.8	18.4	16.10	13.75
	MV16C	21	FC/MC48C	800	26.2	18.7	16.50	14.00
YCJF30S41S1	MV12B	17	FC/MC30B	1000	29.4	21.0	15.00	12.85
	MV12B	17	FC/MC35B	1000	29.6	21.4	15.25	13.00
	MV16C	21	FC/MC35C	1000	29.6	21.4	15.50	13.25
	MV12B	17	FC/MC36B	1000	29.6	21.4	15.30	13.15
	MV16C	21	FC/MC36C	1000	29.6	21.4	15.50	13.15
	MV12B	17	FC/MC43B	1000	30.2	22.0	15.75	13.25
	MV16C	21	FC/MC43C	1000	30.2	22.0	16.00	13.50
	MV16C	21	FC/MC48C	1000	30.6	22.2	16.00	13.50
YCJF36S41S1	MV20D	24	FC/MC48D	1000	30.6	22.2	16.00	13.50
	MV12B	17	FC/MC35B	1200	35.0	25.8	15.00	12.50
	MV16C	21	FC/MC35C	1200	35.2	26.0	15.75	13.00
	MV12B	17	FC/MC36B	1200	34.8	25.4	15.00	12.75
	MV16C	21	FC/MC36C	1200	35.0	25.6	15.50	13.00
	MV12B	17	FC/MC43B	1200	35.8	26.4	15.50	13.00
	MV16C	21	FC/MC43C	1200	36.0	26.6	16.00	13.25
	MV12D	24	FC/MC48D	1150	36.0	26.4	16.00	13.50
MV16C	21	FC/MC48C	1200	36.2	27.0	16.25	14.00	
MV20D	24	FC/MC48D	1200	36.2	27.0	16.25	14.00	

For notes see Page 6.

COOLING CAPACITY - With Air Handler Coils (Continued)

UNIT MODEL	AIR HANDLER		COIL MODEL ¹	COOLING				
	MODEL	W		RATED CFM	NET MBH		SEER	EER
					TOTAL	SENS.		
14.5 SEER AC WITH MV - VARIABLE SPEED (Continued)								
YCJF42S41S1	MV16C	21	FC/MC43C	1400	41.0	30.8	15.00	12.75
	MV16C	21	FC/MC48C	1400	41.5	31.2	15.50	13.00
	MV20D	24	FC/MC48D	1400	42.0	31.4	15.50	13.00
	MV20D	24	FC/MC60D	1400	41.5	31.4	15.50	13.00
	MV20D	24	FC/MC62D	1400	42.0	31.4	15.75	13.00
YCJF48S41S1	MV16C	21	FC/MC48C	1600	47.0	33.0	15.25	12.75
	MV20D	24	FC/MC48D	1600	47.0	33.0	15.25	12.75
	MV20D	24	FC/MC60D	1600	47.0	33.0	15.25	12.75
	MV20D	24	FC/MC62D	1600	47.5	33.2	15.25	12.75
YCJF60S41S1	MV20D	24	FC/MC60D	1800	55.0	39.0	14.00	11.95
	MV20D	24	FC/MC62D	1800	57.0	39.5	14.50	12.25
14.5 SEER AC WITH AV / SV / F*FV - VARIABLE SPEED								
YCJF24S41S1	AV24	17	-	750	25.0	17.5	15.75	13.25
	AV36	21	-	750	25.8	18.2	16.50	13.75
YCJF30S41S1	AV36	21	-	1000	30.4	22.4	16.25	13.50
YCJF36S41S1	AV36	21	-	1250	36.2	27.4	15.75	13.25
	AV/SV48	24	-	1200	34.4	25.4	15.25	13.00
	F4FV060	24	-	1200	34.6	25.6	15.50	13.25
YCJF42S41S1	AV/SV48	24	-	1400	40.0	29.4	14.75	12.50
	AV/SV60	24	-	1400	40.0	29.4	14.75	12.50
	F4FV060	24	-	1350	40.0	29.6	15.00	12.50
YCJF48S41S1	AV/SV48	24	-	1600	44.5	30.8	14.25	12.00
	AV/SV60	24	-	1650	44.0	30.6	14.25	12.00
	F4FV060	24	-	1600	44.5	30.6	14.25	12.00
YCJF60S41S1	AV/SV60	24	-	1750	55.0	39.0	14.00	12.00
14.5 SEER AC WITH AHP / SHP / F*FP								
YCJF24S41S1	AHP24	17	-	850	24.8	17.4	14.30	12.20
	F4FP030	17	-	800	24.8	17.2	14.30	12.20
YCJF30S41S1	AHP36	21	-	1000	29.6	21.4	14.30	12.20
YCJF36S41S1	AHP36	21	-	1200	35.4	26.2	15.00	12.50
	F4FP036	21	-	1200	34.2	25.2	14.00	12.00
	F4FP040	21	-	1200	34.4	25.0	14.00	12.00
	F4FP042	21	-	1200	34.4	25.0	14.00	12.00
	F5FP048	24	-	1250	36.4	27.4	16.25	13.50
	F5FP060	24	-	1250	34.8	26.0	15.25	13.00
YCJF42S41S1	F5FP048	24	-	1450	42.0	32.0	15.50	13.00
	F5FP060	24	-	1500	40.0	29.8	14.75	12.50
YCJF48S41S1	AHP/SHP60	24	-	1600	44.0	30.6	14.20	12.00
	F5FP048	24	-	1700	47.5	34.0	15.00	12.75
	F5FP060	24	-	1700	44.5	31.2	14.00	12.00

Rated in accordance with DOE test procedures (Federal Register 12-27-79 and 3-18-88) and ARI Standards 210.

Cooling MBH based on 80°F entering air temperature, 50% RH, and rated air flow.

EER (Energy Efficiency Ratio) is the total cooling output in BTU's at 95°F outdoor ambient divided by the total electric power in watt-hours at those conditions.

SEER (Seasonal Energy Efficiency Ratio) is the total cooling output in BTU's during a normal annual usage period for cooling divided by the total electric power input in watt-hours during the same period.

1. MC coils available with a factory installed horizontal drain pan. See price pages for specific model number.

— = Not applicable.

COOLING CAPACITY - Upflow, Downflow & Horizontal Furnaces and Coils

UNIT MODEL	FURNACE**		COIL MODEL	COOLING				
	CFM RANGE (Min.-max.)	W		RATED CFM	NET MBH		SEER ¹	EER
					TOTAL	SENS.		
YCJF24S41S1	600 - 1000	14,17	FC/MC/PC24	800	24.8	17.3	14.00	12.00
	600 - 1000	14,17	FC/MC/PC30	800	24.8	17.3	14.00	12.00
	600 - 1000	14	FC/MC/PC32	800	25	17.6	14.50	12.35
	600 - 1000	17,21	FC/MC/PC35	800	25	17.6	14.50	12.35
	600 - 1000	14,17,21	FC/MC/PC36	800	25	17.6	14.00	12.00
	600 - 1000	14	FC/MC/PC37	800	25.4	17.9	14.50	12.35
	600 - 1000	17,21	FC/MC/PC43	800	25.2	18	14.70	12.50
	600 - 1000	21	FC/MC/PC48	800	25.6	18.3	14.80	12.65
	600 - 1000	14	HC18	800	24.2	16.7	14.00	12.00
	600 - 1000	14	HC30	800	24.8	17.4	14.00	12.00
	600 - 1000	17	HC36	800	25	17.6	14.00	12.00
	600 - 1000	21	HC42	800	25.4	18	14.50	12.35
	600 - 1000	14,17	HD24	800	25.4	17.7	14.50	12.35
	600 - 1000	14,17,21	HD36	800	24.8	17	14.00	12.00
	600 - 1000	21	HD48	800	25.6	17.9	14.50	12.35
600 - 1000	14,17	UC24	800	25	17.5	14.00	12.00	
600 - 1000	14,17	UC30	800	25	17.5	14.00	12.00	
YCJF30S41S1	800 - 1200	14,17	FC/MC/PC30	1000	28.8	20.6	14.00	12.00
	800 - 1200	14,17	FC/MC/PC32	1000	29	21	14.00	12.00
	800 - 1200	17,21	FC/MC/PC35	1000	29	21	14.00	12.00
	800 - 1200	14,17,21	FC/MC/PC36	1000	29	21	14.00	12.00
	800 - 1200	14	FC/MC/PC37	1000	29.6	21.6	14.50	12.35
	800 - 1200	17,21	FC/MC/PC43	1000	29.6	21.6	14.50	12.35
	800 - 1200	21,24	FC/MC/PC48	1000	30	21.8	14.50	12.35
	800 - 1200	17	HC36	1000	29	21	14.00	12.00
	800 - 1200	21	HC42	1000	29.6	21.6	14.25	12.10
	800 - 1200	14,17,21	HD36	1000	28.8	20.2	14.00	12.00
	800 - 1200	21,24	HD48	1000	29.8	21.4	14.50	12.35
800 - 1200	14,17	UC30	1000	29	20.8	14.00	12.00	
YCJF36S41S1	1000 - 1400	17,21	FC/MC/PC35	1200	33.6	24.6	14.00	11.90
	1000 - 1400	14,17,21	FC/MC/PC36	1200	33.4	24.2	14.00	11.85
	1000 - 1400	14	FC/MC/PC37	1200	34.4	25.2	14.50	12.20
	1000 - 1400	17,21	FC/MC/PC43	1200	34.4	25.2	14.50	12.20
	1000 - 1400	21,24	FC/MC/PC48	1200	34.6	25.4	14.50	12.25
	1000 - 1400	17	HC36	1200	33.6	24.6	14.00	11.90
	1000 - 1400	21	HC42	1200	34.4	25.2	14.50	12.20
	1000 - 1400	14,17,21,24	HD48	1200	34.6	25	14.50	12.20
1000 - 1400	21,24	UC60	1200	33.2	23.8	14.00	11.75	
YCJF42S41S1	1200 - 1600	17,21	FC/MC/PC43	1400.00	40.50	30.40	14.00	12.00
	1200 - 1600	21,24	FC/MC/PC48	1400.00	41.00	30.80	14.50	12.30
	1200 - 1600	21,24	FC/MC/PC60	1400.00	41.00	30.80	14.50	12.30
	1200 - 1600	21	HC42	1400.00	40.50	30.40	14.00	12.00
	1200 - 1600	14,17,21,24	HD48	1400.00	41.00	30.40	14.25	12.10
	1200 - 1600	21,24	HD60	1400.00	41.50	31.20	14.50	12.30
1200 - 1600	21,24	FC/MC62	1400.00	41.00	31.00	14.50	12.30	
YCJF48S41S1	1400 - 1800	21,24	FC/MC/PC48	1600.00	46.50	32.80	14.25	12.10
	1400 - 1800	21,24	FC/MC/PC60	1600.00	46.50	32.60	14.50	12.35
	1400 - 1800	14,17,21,24	HD48	1600.00	46.50	32.60	14.50	12.35
	1400 - 1800	14,17,21,24	HD60	1600.00	47.50	33.20	14.50	12.35
	1400 - 1800	21,24	FC/MC62	1600.00	47.00	32.80	14.50	12.35
YCJF60S41S1	1600 - 2000	21,24	FC/MC/PC60	1800.00	54.50	38.50	13.80	11.90
	1600 - 2000	24	HC60	1800.00	54.50	38.50	13.50	11.65
	1600 - 2000	21,24	FC/MC62	1800.00	57.00	39.00	14.00	12.10

1. Requires a 2FD06700224 Blower Time Delay unless a standard furnace is equipped with one.

** Refer to Quick Selection Chart for specific furnace match-up.

COOLING CAPACITY - With Variable Speed Furnaces

UNIT MODEL	VARIABLE SPEED FURNACE MODEL	COIL MODEL ¹	W	COOLING				
				RATED CFM	Net MBH		SEER	EER
					TOTAL	SENS.		
14.5 SEER AC WITH VARIABLE SPEED FURNACES²								
YCJF24S41S1	PV8*A12	FC/MC/PC24A	14	750	24.8	17.5	15.75	12.25
	PV9*A12	FC/MC/PC24A	14	800	25.2	17.6	15.50	13.25
	P(C,V)9*B12	FC/MC/PC24B	17	800	25.4	17.6	15.75	13.25
	PV8*A12	FC/MC/PC30A	14	750	24.8	17.5	15.75	13.25
	PV9*A12	FC/MC/PC30A	14	800	25.2	17.6	15.50	13.25
	P(C,V)9*B12	FC/MC/PC30B	17	800	25.4	17.6	15.75	13.25
	PV8*A12	FC/MC/PC32A	14	750	25.2	17.6	16.00	13.50
	PV9*A12	FC/MC/PC32A	14	800	25.4	17.8	15.25	13.00
	P(C,V)9*B12	FC/MC/PC35B	17	800	25.4	17.9	15.75	13.25
	P(C,V)9*C16	FC/MC/PC35C	21	850	25.8	18.6	16.25	13.75
	PV8*A12	FC/MC/PC36A	14	750	25.2	17.6	16.00	13.50
	PV9*A12	FC/MC/PC36A	14	800	25.4	17.9	15.75	13.25
	P(C,V)9*B12	FC/MC/PC36B	17	800	25.6	17.9	15.75	13.50
	P(C,V)9*C16	FC/MC/PC36C	21	850	25.8	18.6	16.00	13.50
	PV8*A12	FC/MC/PC37A	14	800	25.8	18.3	16.00	13.50
	PV9*A12	FC/MC/PC37A	14	800	25.8	18.2	15.75	13.25
	P(C,V)9*B12	FC/MC/PC43B	17	800	25.8	18.3	16.00	13.50
	P(C,V)9*C16	FC/MC/PC43C	21	850	26.4	18.9	16.25	13.75
	P(C,V)9*C16	FC/MC/PC48C	21	850	26.6	19.2	16.50	14.00
	PV8*A12	HC24A	14	750	24.4	16.8	15.25	13.00
	PV9*A12	HC24A	14	800	24.4	16.9	14.75	12.50
	PV8*A12	HC30A	14	750	24.8	17.4	15.75	13.25
	PV9*A12	HC30A	14	800	25.2	17.7	15.50	13.25
	P(C,V)9*B12	HC36B	17	800	25.4	17.9	15.75	13.50
	P(C,V)9*C16	HC42C	21	850	26.4	18.9	16.25	13.75
	PV8*A12	HD24	14	750	25.8	17.8	16.25	13.75
	PV9*A12	HD24	14	800	25.8	18.0	16.00	13.50
	PV8*A12	HD36	14	750	25.0	17.0	15.50	13.25
	PV9*A12	HD36	14	800	25.2	17.2	15.50	13.25
	P(C,V)9*B12	HD36	17	800	25.2	17.3	15.50	13.25
	P(C,V)9*C16	HD48	21	850	26.4	19.0	16.50	14.00
	PV8*A12	UC24A	14	750	25.2	17.5	16.00	13.50
PV9*A12	UC24A	14	800	25.4	17.8	15.75	13.25	
P(C,V)9*B12	UC24B	17	800	25.4	17.8	15.75	13.25	
PV8*A12	UC30A	14	750	25.2	17.5	15.75	13.25	
PV9*A12	UC30A	14	800	25.4	17.8	15.75	13.25	
P(C,V)9*B12	UC30B	17	800	25.4	17.8	15.75	13.25	
YCJF30S41S1	PV8*A12	FC/MC/PC30A	14	1000	29.2	21.0	15.00	12.75
	PV8*B16	FC/MC/PC30B	17	1050	29.6	21.6	15.25	13.00
	PV9*A12	FC/MC/PC30A	14	1000	29.2	20.8	15.00	12.75
	P(C,V)9*B12	FC/MC/PC30B	17	1000	29.4	21.0	15.25	13.00
	PV8*A12	FC/MC/PC32A	14	1000	29.6	21.4	15.25	13.00
	PV9*A12	FC/MC/PC32A	14	1000	29.4	21.4	15.00	12.75
	PV8*B16	FC/MC/PC35B	17	1050	30.0	22.0	15.75	13.25
	PV8*C16	FC/MC/PC35C	21	1000	29.8	21.6	15.75	13.25
	PV8*C20	FC/MC/PC35C	21	1100	30.2	22.8	15.75	13.25
	P(C,V)9*B12	FC/MC/PC35B	17	1000	29.6	21.4	15.50	13.00
	P(C,V)9*C16	FC/MC/PC35C	21	1000	29.6	21.4	15.50	13.00
	P(C,V)9*C20	FC/MC/PC35C	21	1050	29.6	21.4	15.25	13.00

For Notes See Page 11.

COOLING CAPACITY - With Variable Speed Furnaces (Continued)

UNIT MODEL	VARIABLE SPEED FURNACE MODEL	COIL MODEL ¹	W	COOLING				
				RATED CFM	Net MBH		SEER	EER
					TOTAL	SENS.		
14.5 SEER AC WITH VARIABLE SPEED FURNACES²								
YCJF30S41S1	PV8*A12	FC/MC/PC36A	14	1000	29.4	21.2	15.25	13.00
	PV8*B16	FC/MC/PC36B	17	1050	29.8	22.0	15.75	13.25
	PV8*C16	FC/MC/PC36C	21	1000	29.6	21.4	15.75	13.25
	PV8*C20	FC/MC/PC36C	21	1100	30.2	22.6	15.75	13.25
	PV9*A12	FC/MC/PC36A	14	1000	29.4	21.2	15.00	12.75
	P(C,V)9*B12	FC/MC/PC36B	17	1000	29.6	21.4	15.50	13.00
	P(C,V)9*C16	FC/MC/PC36C	21	1000	29.6	21.4	15.50	13.00
	P(C,V)9*C20	FC/MC/PC36C	21	1050	29.6	21.4	15.50	13.00
	PV8*A12	FC/MC/PC37A	14	1000	30.0	21.8	15.25	13.00
	PV9*A12	FC/MC/PC37A	14	1000	30.0	21.8	15.00	12.75
	PV8*B16	FC/MC/PC43B	17	1050	30.6	22.6	16.25	13.50
	PV8*C16	FC/MC/PC43C	21	1000	30.2	22.0	16.25	13.50
	PV8*C20	FC/MC/PC43C	21	1100	30.8	23.4	16.25	13.75
	P(C,V)9*B12	FC/MC/PC43B	17	1000	30.2	22.0	16.00	13.25
	P(C,V)9*C16	FC/MC/PC43C	21	1000	30.2	22.0	16.00	13.25
	P(C,V)9*C20	FC/MC/PC43C	21	1050	30.2	22.0	16.00	13.25
	PV8*C16	FC/MC/PC48C	21	1000	30.6	22.2	16.25	13.75
	PV8*C20	FC/MC/PC48C	21	1100	31.2	23.6	16.50	13.75
	P(C,V)9*C16	FC/MC/PC48C	21	1000	30.4	22.2	16.00	13.50
	P(C,V)9*C20	FC/MC/PC48C	21	1050	30.4	22.2	16.00	13.50
	P(C,V)9*D20	FC/MC/PC48D	24	1050	30.8	22.8	16.25	13.75
	PV9*A12	HC30A	14	1000	29.0	21.0	15.00	12.50
	PV8*B16	HC36B	17	1050	30.0	22.0	15.75	13.25
	P(C,V)9*B12	HC36B	17	1000	29.6	21.4	15.50	13.25
	PV8*C16	HC42C	21	1000	30.2	22.0	16.25	13.50
	PV8*C20	HC42C	21	1100	31.0	23.4	16.25	13.75
	P(C,V)9*C16	HC42C	21	1000	30.2	22.0	15.75	13.25
	P(C,V)9*C20	HC42C	21	1050	30.2	22.0	15.75	13.25
	PV8*A12	HD36	14	1000	29.2	20.6	15.00	12.75
	PV8*B16	HD36	17	1050	29.6	21.6	15.50	13.25
	PV8*C16	HD36	21	1000	29.4	20.8	15.75	13.25
	PV8*C20	HD36	21	1100	30.0	22.0	16.00	13.50
	PV9*A12	HD36	14	1000	29.2	20.6	14.75	12.75
	P(C,V)9*B12	HD36	17	1000	29.4	20.6	15.25	13.00
	PV8*C16	HD48	21	1000	30.6	21.8	16.50	13.75
	PV8*C20	HD48	21	1100	31.2	23.2	16.50	14.00
	P(C,V)9*C16	HD48	21	1000	30.4	21.8	16.00	13.50
	P(C,V)9*C20	HD48	21	1050	30.4	21.8	16.00	13.50
	P(C,V)9*D20	HD48	24	1050	30.6	22.6	16.25	13.50
	PV8*A12	UC30A	14	1000	29.4	21.2	15.25	13.00
PV8*B16	UC30B	17	1050	29.8	21.8	15.50	13.25	
PV9*A12	UC30A	14	1000	29.4	21.2	15.00	12.75	
YCJF36S41S1	PV8*B16	FC/MC/PC35B	17	1200	34.2	25.0	15.25	12.75
	PV8*C16	FC/MC/PC35C	21	1200	34.2	25.0	15.50	12.75
	PV8*C20	FC/MC/PC35C	21	1200	34.2	25.0	15.50	12.75
	P(C,V)9*B12	FC/MC/PC35B	17	1200	34.0	24.8	14.75	12.25
	P(C,V)9*C16	FC/MC/PC35C	21	1200	34.2	25.0	15.25	12.75
	P(C,V)9*C20	FC/MC/PC35C	21	1200	34.2	25.0	15.25	12.75
	PV8*A12	FC/MC/PC36A	14	1200	33.8	24.4	14.50	12.25
	PV8*B16	FC/MC/PC36B	17	1200	34.0	24.6	15.00	12.75
	PV8*C16	FC/MC/PC36C	21	1200	34.0	24.6	15.25	12.75

For Notes See Page 11.

COOLING CAPACITY - With Variable Speed Furnaces (Continued)

UNIT MODEL	VARIABLE SPEED FURNACE MODEL	COIL MODEL ¹	W	COOLING				
				RATED CFM	Net MBH		SEER	EER
					TOTAL	SENS.		
14.5 SEER AC WITH VARIABLE SPEED FURNACES²								
YCJF36S41S1	PV8*C20	FC/MC/PC36C	21	1200	34.0	24.6	15.25	12.75
	PV9*A12	FC/MC/PC36A	14	1200	33.6	24.2	14.25	12.00
	P(C,V)9*B12	FC/MC/PC36B	17	1200	33.8	24.4	14.75	12.25
	P(C,V)9*C16	FC/MC/PC36C	21	1200	34.0	24.6	15.25	12.75
	P(C,V)9*C20	FC/MC/PC36C	21	1200	34.0	24.6	15.00	12.75
	PV8*A12	FC/MC/PC37A	14	1150	34.6	25.2	14.75	12.25
	PV9*A12	FC/MC/PC37A	14	1100	34.0	24.4	14.75	12.25
	PV8*B16	FC/MC/PC43B	17	1200	35.0	25.4	15.75	13.00
	PV8*C16	FC/MC/PC43C	21	1200	35.0	25.6	15.75	13.00
	PV8*C20	FC/MC/PC43C	21	1200	35.0	25.6	16.00	13.25
	P(C,V)9*B12	FC/MC/PC43B	17	1200	34.6	25.4	15.00	12.50
	P(C,V)9*C16	FC/MC/PC43C	21	1200	35.0	25.6	15.75	13.00
	P(C,V)9*C20	FC/MC/PC43C	21	1200	34.8	25.4	15.50	13.00
	PV8*C16	FC/MC/PC48C	21	1200	35.4	26.0	16.25	13.25
	PV8*C20	FC/MC/PC48C	21	1200	35.4	26.0	16.25	13.25
	P(C,V)9*C16	FC/MC/PC48C	21	1200	35.2	25.8	16.00	13.25
	P(C,V)9*C20	FC/MC/PC48C	21	1200	35.2	25.8	15.75	13.00
	P(C,V)9*D20	FC/MC/PC48D	24	1200	35.2	25.8	16.00	13.25
	PV8*B16	HC36B	17	1200	34.2	25.0	15.25	12.75
	P(C,V)9*B12	HC36B	17	1200	34.0	24.8	15.00	12.50
	PV8*C16	HC42C	21	1200	35.0	25.6	15.75	13.25
	PV8*C20	HC42C	21	1200	35.0	25.6	16.00	13.25
	P(C,V)9*C16	HC42C	21	1200	35.0	25.6	15.75	13.00
	P(C,V)9*C20	HC42C	21	1200	34.8	25.4	15.50	13.00
	PV8*C16	HD48	21	1200	35.2	25.6	16.00	13.25
	PV8*C20	HD48	21	1200	35.2	25.6	16.00	13.50
	P(C,V)9*C16	HD48	21	1200	35.2	25.4	15.75	13.25
	P(C,V)9*C20	HD48	21	1200	35.0	25.4	15.75	13.00
	P(C,V)9*D20	HD48	24	1200	35.2	25.4	15.75	13.25
	PV8*C20	FC/MC62D	21	1200	35.6	26.0	16.25	13.50
	P(C,V)9*C16	FC/MC62D	21	1200	35.4	26.0	16.00	13.25
	P(C,V)9*C20	FC/MC62D	21	1200	35.4	26.0	15.75	13.25
P(C,V)9*D20	FC/MC62D	24	1200	35.4	26.0	16.00	13.25	
PV8*C16	UC60C	21	1200	33.8	24.2	15.50	12.75	
PV8*C20	UC60C	21	1200	33.8	24.2	15.50	12.75	
P(C,V)9*C16	UC60C	21	1200	33.8	24.2	15.25	12.75	
P(C,V)9*C20	UC60C	21	1200	33.6	24.2	15.25	12.50	
P(C,V)9*D20	UC60D	24	1200	33.8	24.2	15.25	12.75	
YCJF42S41S1	PV8*B16	FC/MC/PC43B	17	1400	41.0	30.6	14.75	12.50
	PV8*C20	FC/MC/PC43C	21	1400	41.0	30.8	14.75	12.75
	P(C,V)9*C16	FC/MC/PC43C	21	1400	41.0	30.6	14.50	12.50
	P(C,V)9*C20	FC/MC/PC43C	21	1350	41.0	30.8	15.00	12.75
	PV8*C16	FC/MC/PC48C	21	1400	41.5	31.2	15.00	12.75
	PV8*C20	FC/MC/PC48C	21	1400	41.5	31.2	15.25	12.75
	P(C,V)9*C16	FC/MC/PC48C	21	1400	41.5	31.0	15.00	12.50
	P(C,V)9*C20	FC/MC/PC48C	21	1350	41.5	31.2	15.25	12.75
	P(C,V)9*D20	FC/MC/PC48D	24	1350	41.5	31.2	15.50	13.00
	PV8*C16	FC/MC/PC60C	21	1400	41.5	31.2	15.00	12.75
	PV8*C20	FC/MC/PC60C	21	1400	41.5	31.2	15.25	12.75
	P(C,V)9*C16	FC/MC/PC60C	21	1400	41.0	31.0	14.75	12.50

For Notes See Page 11.

COOLING CAPACITY - With Variable Speed Furnaces (Continued)

UNIT MODEL	VARIABLE SPEED FURNACE MODEL	COIL MODEL ¹	W	COOLING				
				RATED CFM	Net MBH		SEER	EER
					TOTAL	SENS.		
14.5 SEER AC WITH VARIABLE SPEED FURNACES²								
YCJF42S41S1	P(C,V)9*C20	FC/MC/PC60C	21	1350	41.5	31.2	15.25	12.75
	P(C,V)9*D20	FC/MC/PC60D	24	1350	41.5	31.2	15.50	13.00
	PV8*C16	HC42C	21	1400	41.0	30.6	15.00	12.50
	PV8*C20	HC42C	21	1400	41.0	30.8	15.00	12.75
	P(C,V)9*C16	HC42C	21	1400	41.0	30.6	14.75	12.50
	P(C,V)9*C20	HC42C	21	1350	41.0	30.8	15.00	12.75
	PV8*C16	HD48	21	1400	41.5	30.6	15.00	12.75
	PV8*C20	HD48	21	1400	41.5	30.8	15.25	12.75
	P(C,V)9*C16	HD48	21	1400	41.0	30.6	14.75	12.50
	P(C,V)9*C20	HD48	21	1350	41.5	30.6	15.25	12.75
	P(C,V)9*D20	HD48	24	1350	41.5	30.8	15.50	13.00
	PV8*C16	HD60	21	1400	42.0	31.4	15.25	13.00
	PV8*C20	HD60	21	1400	42.0	31.6	15.50	13.00
	P(C,V)9*C16	HD60	21	1400	42.0	31.4	15.00	12.75
	P(C,V)9*C20	HD60	21	1350	42.0	31.6	15.50	13.00
	P(C,V)9*D20	HD60	24	1350	42.0	31.6	15.75	13.25
	PV8*C20	FC/MC62D	21	1400	41.5	31.2	15.50	13.00
	P(C,V)9*C16	FC/MC62D	21	1400	41.5	31.2	15.00	12.75
	P(C,V)9*C20	FC/MC62D	21	1350	41.5	31.2	15.25	13.00
	P(C,V)9*D20	FC/MC62D	24	1350	42.0	31.4	15.75	13.00
YCJF48S41S1	PV8*C16	FC/MC/PC48C	21	1500	46.5	31.8	14.50	12.25
	PV8*C20	FC/MC/PC48C	21	1600	47.0	32.8	14.75	12.50
	P(C,V)9*C16	FC/MC/PC48C	21	1600	46.5	32.8	14.50	12.25
	P(C,V)9*C20	FC/MC/PC48C	21	1600	47.0	32.8	14.75	12.50
	PV8*C16	FC/MC/PC60C	21	1500	46.5	32.0	14.50	12.25
	PV8*C20	FC/MC/PC60C	21	1600	47.0	32.8	14.75	12.50
	P(C,V)9*C16	FC/MC/PC60C	21	1600	46.5	32.8	14.50	12.25
	P(C,V)9*C20	FC/MC/PC60C	21	1600	47.0	32.8	14.75	12.50
	P(C,V)9*D20	FC/MC/PC60D	24	1550	47.0	33.0	15.00	12.75
	PV8*C16	HD48	21	1500	46.5	31.6	14.50	12.25
	PV8*C20	HD48	21	1600	47.0	32.8	14.75	12.50
	P(C,V)9*C16	HD48	21	1600	46.5	32.6	14.50	12.25
	P(C,V)9*C20	HD48	21	1600	47.0	32.6	14.75	12.50
	P(C,V)9*D20	HD48	24	1550	47.0	32.8	15.00	12.75
	PV8*C16	HD60	21	1500	47.0	32.4	15.00	12.50
	PV8*C20	HD60	21	1600	47.5	33.4	15.00	12.75
	P(C,V)9*C16	HD60	21	1600	47.5	33.2	14.75	12.50
	P(C,V)9*C20	HD60	21	1600	47.5	33.4	15.00	12.75
	P(C,V)9*D20	HD60	24	1550	48.0	33.6	15.25	13.00
	PV8*C20	FC/MC62D	21	1600	47.0	33.0	15.00	12.75
P(C,V)9*C16	FC/MC62D	21	1600	47.0	32.8	14.75	12.25	
P(C,V)9*C20	FC/MC62D	21	1600	47.0	33.0	15.00	12.50	
P(C,V)9*D20	FC/MC62D	24	1550	47.5	33.0	15.25	12.75	
YCJF60S41S1	P(C,V)9*D20	HC60D	24	1600	53.5	36.4	13.50	11.75
	PV8*C20	HD60	21	1750	56.5	39.0	13.75	12.00
	P(C,V)9*C20	HD60	21	1650	56.5	39.0	14.00	12.25
	P(C,V)9*D20	HD60	24	1600	56.0	37.8	14.25	12.25
	PV8*C20	FC/MC62D	21	1750	57.0	39.5	14.25	12.25
	P(C,V)9*C20	FC/MC62D	21	1650	56.0	38.0	13.75	12.00
P(C,V)9*D20	FC/MC62D	24	1600	56.0	37.8	14.00	12.25	

1. MC coils available with a factory installed horizontal drain pan. See price pages for specific model number.

2. Variable speed furnaces have B.O.D (Blower on Delay) standard.

ACCESSORIES

Refer to Price Manual for specific model numbers.

OFF CYCLE TIMER DELAY - Provides a 5-minute off cycle to prevent rapid recycling of the compressor.

ROOM THERMOSTATS - A wide selection of compatible thermostats are available to provide optimum performance and features for any installation.

1H/1C, manual changeover electronic non-programmable thermostat.

1H/1C, auto/manual changeover, electronic programmable, deluxe 7-day, thermostat.

1H/1C, auto/manual changeover, electronic programmable.

* For the most current accessory information, refer to the price book or consult factory.

SOUND POWER RATINGS*

UNIT MODEL	(dBA)
24	71
30	72
36	72
42	72
48	73
60	74

* Rated in accordance with ARI 270-95 Standards.

TYPICAL INSTALLATION

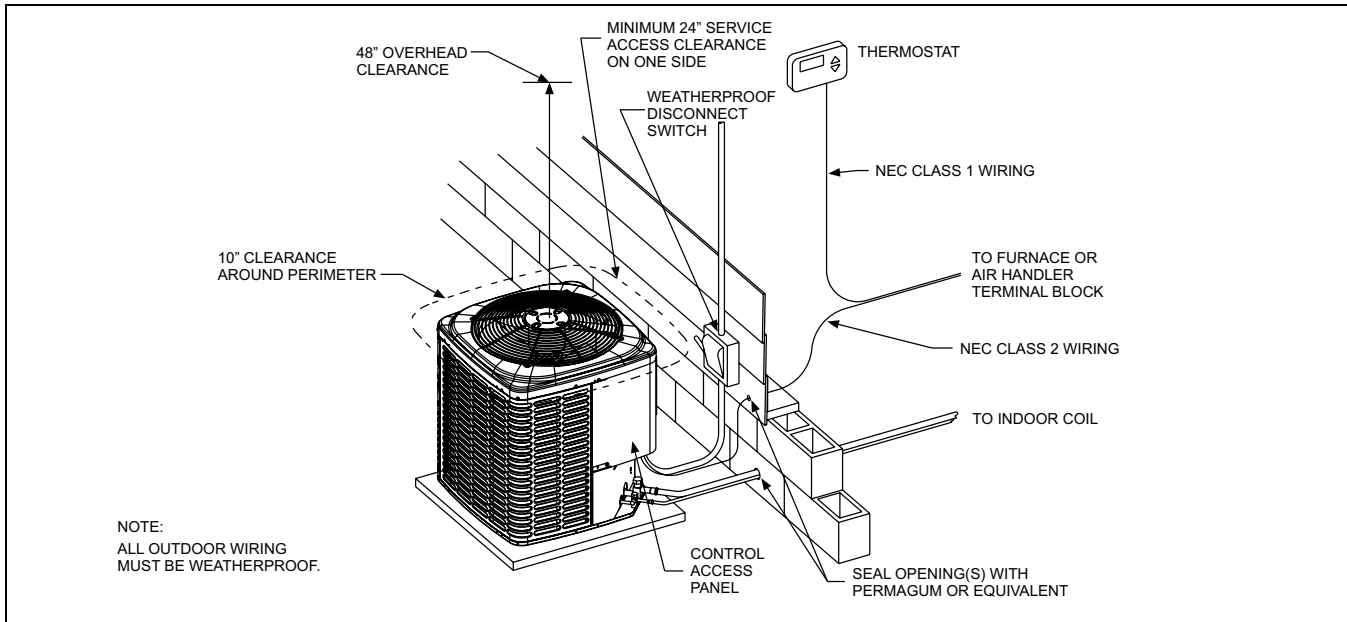

TYPICAL FIELD WIRING

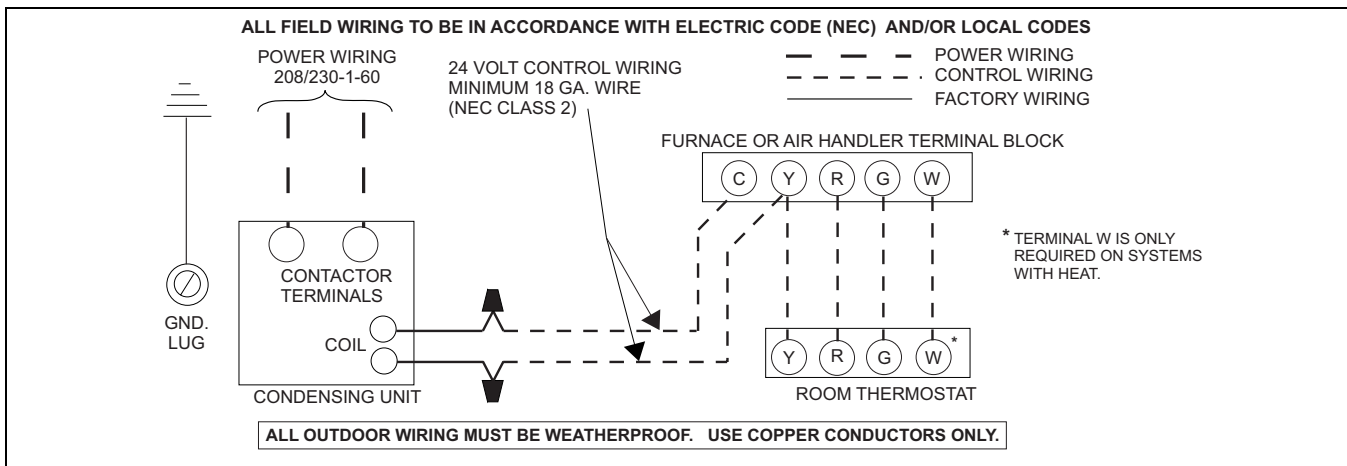

COOLING PERFORMANCE DATA																
AIR CONDITIONER MODEL NO.		YCJF24S41S1														
INDOOR COIL MODEL NO.		FC/MC/PC32														
CONDENSING ENTERING AIR TEMPERATURE	IDCFM	600					800					1000				
	ID DB (°F)	80	80	75	80	80	80	80	75	80	80	80	80	75	80	80
	ID WB (°F)	57	62	62	67	72	57	62	62	67	72	57	62	62	67	72
65	T.C.	21.8	23.8	23.8	25.7	27.7	23.9	25.4	25.3	27.6	29.5	26.1	27.1	26.9	29.4	31.4
	S.C.	16.3	16.3	16.3	16.1	14.4	16.3	16.3	16.3	16.2	15.3	16.3	16.3	16.3	16.3	16.2
	KW	1.2	1.2	1.2	1.2	1.2	1.2	1.2	1.2	1.2	1.2	1.2	1.2	1.2	1.2	1.2
75	T.C.	21.0	23.0	22.9	24.9	26.8	23.1	24.6	24.4	26.6	28.6	25.3	26.1	25.9	28.4	30.4
	S.C.	16.3	16.3	15.8	15.7	13.9	16.3	16.3	16.0	16.0	14.9	16.3	16.3	16.3	16.3	15.9
	KW	1.4	1.4	1.4	1.4	1.4	1.4	1.4	1.4	1.4	1.4	1.4	1.4	1.4	1.4	1.4
85	T.C.	20.2	22.2	22.0	24.1	25.9	22.4	23.7	23.5	25.7	27.7	24.5	25.2	24.9	27.3	29.5
	S.C.	16.3	16.3	15.2	15.3	13.4	16.3	16.3	15.8	15.8	14.4	16.3	16.3	16.3	16.3	15.5
	KW	1.6	1.6	1.6	1.6	1.6	1.6	1.6	1.6	1.6	1.6	1.6	1.6	1.6	1.6	1.6
95	T.C.	19.5	21.4	21.2	23.3	25.0	21.6	22.8	22.6	24.8	26.8	23.7	24.2	23.9	26.3	28.5
	S.C.	16.3	16.3	14.7	15.0	12.9	16.3	16.3	15.5	15.6	14.0	16.3	16.3	16.3	16.3	15.1
	KW	1.8	1.8	1.8	1.8	1.8	1.8	1.8	1.8	1.8	1.8	1.8	1.8	1.8	1.8	1.8
105	T.C.	18.4	20.1	19.9	22.0	23.7	20.4	21.4	21.1	23.4	25.2	22.4	22.6	22.4	24.7	26.8
	S.C.	16.3	15.9	14.0	14.2	12.2	16.3	16.1	15.2	15.3	13.3	16.3	16.3	16.3	16.3	14.4
	KW	2.2	2.1	2.1	2.1	2.1	2.1	2.1	2.1	2.1	2.1	2.1	2.1	2.1	2.1	2.2
115	T.C.	17.4	18.8	18.6	20.7	22.3	19.3	19.9	19.7	21.9	23.7	21.2	21.0	20.9	23.1	25.1
	S.C.	16.3	15.4	13.4	13.5	11.6	16.3	15.9	14.8	14.9	12.6	16.3	16.3	16.3	16.3	13.6
	KW	2.5	2.5	2.5	2.5	2.5	2.5	2.5	2.5	2.5	2.5	2.5	2.5	2.5	2.5	2.5
125	T.C.	16.3	17.5	17.3	19.3	20.9	18.1	18.4	18.3	20.4	22.2	19.9	19.4	19.3	21.6	23.4
	S.C.	16.3	15.0	12.7	12.8	10.9	16.3	15.7	14.5	14.6	11.9	16.3	16.3	16.3	16.3	12.9
	KW	2.9	2.9	2.9	2.9	2.8	2.9	2.9	2.9	2.9	2.8	2.8	2.8	2.8	2.9	2.8

NOTE: ALL CAPACITIES INCLUDE INDOOR FAN HEAT AT 1250 BTUH/1000 CFM.

Multipliers for determining the performance with other indoor sections.

For dry bulb temperatures different than those listed (between 73-87 F), sensible capacity increases by 1060 BTUH per 1000 CFM per degree above the listed temperature and decreases by 1060 BTUH per 1000 CFM per degree below the listed temperature.

Air Handler	Coil	T.C.	S.C.	KW
-	FC/MC/PC24	1.02	1.04	1.02
-	FC/MC/PC30	1.02	1.04	1.02
-	FC/MC/PC35	1.02	1.06	1.02
-	FC/MC/PC36	1.02	1.06	1.02
-	FC/MC/PC37	1.04	1.08	1.02
-	FC/MC/PC43	1.03	1.08	1.02
-	FC/MC/PC48	1.05	1.10	1.02
-	HC24	0.99	1.00	1.02
-	HC30	1.01	1.04	1.02
-	HC36	1.02	1.06	1.02
-	HC42	1.04	1.08	1.02
-	HD24	1.04	1.07	1.02
-	HD36	1.01	1.02	1.02
-	HD48	1.05	1.07	1.02
-	UC24	1.02	1.05	1.02
-	UC30	1.02	1.05	1.02
AHP24	-	1.01	1.04	1.01
AV24	-	1.02	1.05	0.93
AV36	-	1.05	1.09	0.93
F4FP030	-	1.02	1.04	1.02
MA08B	FC/MC24B	1.02	1.04	1.02
MV12B	FC/MC24B	1.04	1.07	0.94
MA08B	FC/MC30B	1.02	1.04	1.02
MV12B	FC/MC30B	1.04	1.07	0.94
MA08B	FC/MC35B	1.02	1.06	1.02
MV12B	FC/MC35B	1.05	1.08	0.93
MV16C	FC/MC35C	1.05	1.08	0.93
MA08B	FC/MC36B	1.02	1.06	1.02
MV12B	FC/MC36B	1.05	1.08	0.93
MV16C	FC/MC36C	1.05	1.08	0.93
MA08B	FC/MC43B	1.03	1.08	1.02
MV12B	FC/MC43B	1.06	1.10	0.94
MV16C	FC/MC43C	1.06	1.10	0.93
MV16C	FC/MC48C	1.07	1.12	0.93

Variable Speed Furnace	Coil	T.C.	S.C.	KW
PV8*A12	FC/MC/PC24A	1.02	1.05	0.94
PV9*A12	FC/MC/PC24A	1.03	1.06	0.96
P(C,V)9*B12	FC/MC/PC24B	1.03	1.06	0.95
PV8*A12	FC/MC/PC30A	1.02	1.05	0.94
PV9*A12	FC/MC/PC30A	1.03	1.06	0.96
P(C,V)9*B12	FC/MC/PC30B	1.03	1.06	0.95
PV8*A12	FC/MC/PC32A	1.03	1.06	0.94
PV9*A12	FC/MC/PC32A	1.03	1.07	0.97
P(C,V)9*B12	FC/MC/PC35B	1.04	1.07	0.95
P(C,V)9*C16	FC/MC/PC35C	1.06	1.12	0.94
PV8*A12	FC/MC/PC36A	1.03	1.06	0.94
PV9*A12	FC/MC/PC36A	1.04	1.07	0.96
P(C,V)9*B12	FC/MC/PC36B	1.04	1.08	0.95
P(C,V)9*C16	FC/MC/PC36C	1.06	1.12	0.94
PV8*A12	FC/MC/PC37A	1.06	1.10	0.95
PV9*A12	FC/MC/PC37A	1.05	1.10	0.96
P(C,V)9*B12	FC/MC/PC43B	1.05	1.10	0.95
P(C,V)9*C16	FC/MC/PC43C	1.08	1.14	0.94
P(C,V)9*C16	FC/MC/PC48C	1.08	1.15	0.94
PV8*A12	HC24A	1.00	1.01	0.94
PV9*A12	HC24A	1.00	1.01	0.97
PV8*A12	HC30A	1.02	1.05	0.94
PV9*A12	HC30A	1.03	1.06	0.96
P(C,V)9*B12	HC36B	1.04	1.08	0.95
P(C,V)9*C16	HC42C	1.08	1.14	0.94
PV8*A12	HD24	1.05	1.07	0.94
PV9*A12	HD24	1.05	1.08	0.96
PV8*A12	HD36	1.02	1.02	0.94
PV9*A12	HD36	1.03	1.04	0.96
P(C,V)9*B12	HD36	1.03	1.04	0.95
P(C,V)9*C16	HD48	1.08	1.14	0.94
PV8*A12	UC24A	1.03	1.05	0.94
PV9*A12	UC24A	1.04	1.07	0.96
P(C,V)9*B12	UC24B	1.04	1.07	0.95
PV8*A12	UC30A	1.03	1.05	0.94
PV9*A12	UC30A	1.04	1.07	0.96
P(C,V)9*B12	UC30B	1.04	1.07	0.95

COOLING PERFORMANCE DATA																
AIR CONDITIONER MODEL NO.		YCJF30S41S1														
INDOOR COIL MODEL NO.		FC/MC/PC43														
CONDENSING ENTERING AIR TEMPERATURE	IDCFM	800					1000					1200				
	ID DB (°F)	80	80	75	80	80	80	80	75	80	80	80	80	75	80	80
	ID WB (°F)	57	62	62	67	72	57	62	62	67	72	57	62	62	67	72
65	T.C.	28.2	30.1	29.9	32.9	35.2	29.8	31.3	31.2	34.1	36.4	31.5	32.5	32.6	35.3	37.5
	S.C.	27.1	24.4	21.3	20.9	17.2	29.1	27.4	23.5	23.3	18.9	31.1	30.4	25.8	25.7	20.6
	KW	1.4	1.4	1.4	1.4	1.4	1.4	1.4	1.4	1.4	1.4	1.4	1.4	1.4	1.4	1.4
75	T.C.	27.3	28.8	28.7	31.4	33.9	28.8	30.0	29.9	32.6	35.0	30.3	31.2	31.0	33.8	36.1
	S.C.	26.2	24.0	20.7	20.4	16.6	28.0	26.7	23.0	22.8	18.3	29.9	29.5	25.2	25.1	19.9
	KW	1.6	1.6	1.6	1.6	1.6	1.6	1.6	1.6	1.6	1.6	1.6	1.6	1.6	1.6	1.6
85	T.C.	26.4	27.5	27.6	29.9	32.5	27.8	28.7	28.6	31.1	33.6	29.2	29.8	29.5	32.3	34.8
	S.C.	25.2	23.5	20.2	19.9	16.0	26.9	26.1	22.4	22.2	17.6	28.7	28.7	24.6	24.5	19.2
	KW	1.8	1.8	1.8	1.8	1.8	1.8	1.8	1.8	1.8	1.8	1.8	1.8	1.8	1.8	1.8
95	T.C.	25.5	26.2	26.5	28.4	31.1	26.8	27.4	27.2	29.6	32.3	28.1	28.5	28.0	30.8	33.4
	S.C.	24.3	23.0	19.6	19.3	15.4	25.9	25.4	21.8	21.6	17.0	27.5	27.9	24.0	23.9	18.5
	KW	2.0	2.0	2.0	2.0	2.0	2.0	2.0	2.0	2.0	2.0	2.0	2.0	2.0	2.0	2.0
105	T.C.	23.9	24.5	24.6	26.9	29.5	25.3	25.9	25.4	28.0	30.6	26.6	27.3	26.2	29.1	31.7
	S.C.	22.8	21.7	18.5	18.7	15.0	24.5	24.1	20.7	21.1	16.6	26.2	26.6	22.9	23.4	18.2
	KW	2.5	2.5	2.5	2.4	2.3	2.4	2.4	2.4	2.4	2.3	2.4	2.4	2.4	2.4	2.3
115	T.C.	22.3	22.7	22.9	25.4	28.0	23.8	24.4	23.6	26.5	29.0	25.2	26.0	24.4	27.5	30.0
	S.C.	21.4	20.5	17.4	18.1	14.6	23.2	22.9	19.6	20.5	16.2	24.9	25.3	21.8	23.0	17.8
	KW	2.9	2.9	2.9	2.7	2.7	2.8	2.8	2.8	2.7	2.7	2.7	2.7	2.7	2.8	2.7
125	T.C.	20.8	21.0	21.1	24.0	26.4	22.3	22.9	21.9	24.9	27.4	23.8	24.8	22.7	25.9	28.3
	S.C.	20.0	19.3	16.3	17.4	14.1	21.9	21.6	18.5	20.0	15.8	23.7	24.0	20.7	22.5	17.5
	KW	3.3	3.3	3.3	3.1	3.0	3.2	3.2	3.2	3.1	3.0	3.0	3.0	3.0	3.2	3.0

NOTE: ALL CAPACITIES INCLUDE INDOOR FAN HEAT AT 1250 BTUH/1000 CFM.

Multipliers for determining the performance with other indoor sections.

NOTE: For dry bulb temperatures different than those listed (between 73-87 F), sensible capacity increases by 1060 BTUH per 1000 CFM per degree above the listed temperature and decreases by 1060 BTUH per 1000 CFM per degree below the listed temperature.

Air Handler	Coil	T.C.	S.C.	KW
-	FC/MC/PC30	0.97	0.95	1.00
-	FC/MC/PC32	0.98	0.98	1.00
-	FC/MC/PC35	0.98	0.98	1.00
-	FC/MC/PC36	0.98	0.97	1.00
-	FC/MC/PC37	1.00	1.00	1.00
-	FC/MC/PC42	0.94	0.95	1.00
-	FC/MC/PC48	1.01	1.01	1.00
-	FC/MC/PC60	1.00	1.01	1.00
-	HC36	0.98	0.98	1.00
-	HC42	1.00	1.00	1.00
-	HD36	0.97	0.94	1.00
-	HD48	1.01	0.99	1.00
-	UC30	0.98	0.96	1.00
AHP36	-	1.00	1.00	1.00
AV36	-	1.03	1.04	0.92
MA12B	FC/MC30B	0.97	0.95	1.00
MV12B	FC/MC30B	0.99	0.97	0.93
MA12B	FC/MC35B	0.98	0.98	1.00
MV12B	FC/MC35B	1.00	0.99	0.93
MV16C	FC/MC35C	1.00	1.00	0.93
MA12B	FC/MC36B	0.98	0.97	1.00
MV12B	FC/MC36B	1.00	0.99	0.93
MV16C	FC/MC36C	1.00	0.99	0.93
MA12B	FC/MC43B	1.00	1.00	1.00
MV12B	FC/MC43B	1.02	1.02	0.93
MV16C	FC/MC43C	1.02	1.02	0.92
MV16C	FC/MC48C	1.03	1.03	0.92
MV20D	FC/MC48D	1.03	1.03	0.93

Variable Speed Furnace	Coil	T.C.	S.C.	KW
PV8*A12	FC/MC/PC30A	0.99	0.97	0.94
PV8*B16	FC/MC/PC30B	1.00	1.00	0.93
PV9*A12	FC/MC/PC30A	0.99	0.97	0.95
P(C,V)9*B12	FC/MC/PC30B	0.99	0.97	0.93
PV8*A12	FC/MC/PC32A	1.00	0.99	0.94
PV9*A12	FC/MC/PC32A	1.00	0.99	0.96
PV8*B16	FC/MC/PC35B	1.01	1.02	0.93
PV8*C16	FC/MC/PC35C	1.00	1.00	0.92
PV8*C20	FC/MC/PC35C	1.02	1.05	0.94
P(C,V)9*B12	FC/MC/PC35B	1.00	0.99	0.94
P(C,V)9*C16	FC/MC/PC35C	1.00	0.99	0.94
P(C,V)9*C20	FC/MC/PC35C	1.00	0.99	0.94
PV8*A12	FC/MC/PC36A	1.00	0.98	0.94
PV8*B16	FC/MC/PC36B	1.01	1.02	0.93
PV8*C16	FC/MC/PC36C	1.00	0.99	0.92
PV8*C20	FC/MC/PC36C	1.02	1.04	0.94
PV9*A12	FC/MC/PC36A	0.99	0.98	0.95
P(C,V)9*B12	FC/MC/PC36B	1.00	0.99	0.93
P(C,V)9*C16	FC/MC/PC36C	1.00	0.99	0.93
P(C,V)9*C20	FC/MC/PC36C	1.00	0.99	0.93
PV8*A12	FC/MC/PC37A	1.01	1.01	0.96
PV9*A12	FC/MC/PC37A	1.01	1.01	0.97
PV8*B16	FC/MC/PC43B	1.03	1.05	0.93
PV8*C16	FC/MC/PC43C	1.02	1.02	0.92
PV8*C20	FC/MC/PC43C	1.04	1.08	0.93
P(C,V)9*B12	FC/MC/PC43B	1.02	1.02	0.93
P(C,V)9*C16	FC/MC/PC43C	1.02	1.02	0.93
P(C,V)9*C20	FC/MC/PC43C	1.02	1.02	0.93
PV8*C16	FC/MC/PC48C	1.03	1.03	0.92
PV8*C20	FC/MC/PC48C	1.05	1.09	0.93
P(C,V)9*C16	FC/MC/PC48C	1.03	1.03	0.93
P(C,V)9*C20	FC/MC/PC48C	1.03	1.03	0.93
P(C,V)9*D20	FC/MC/PC48D	1.04	1.06	0.93
PV9*A12	HC30A	0.98	0.97	0.95
PV8*B16	HC36B	1.01	1.02	0.93
P(C,V)9*B12	HC36B	1.00	0.99	0.93
PV8*C16	HC42C	1.02	1.02	0.92
PV8*C20	HC42C	1.05	1.08	0.93
P(C,V)9*C16	HC42C	1.02	1.01	0.93
P(C,V)9*C20	HC42C	1.02	1.01	0.93
PV8*A12	HD36	0.99	0.96	0.94
PV8*B16	HD36	1.00	1.00	0.93
PV8*C16	HD36	1.00	0.96	0.92
PV8*C20	HD36	1.01	1.02	0.92
PV9*A12	HD36	0.99	0.95	0.95
P(C,V)9*B12	HD36	0.99	0.96	0.93
PV8*C16	HD48	1.03	1.01	0.92
PV8*C20	HD48	1.05	1.08	0.92
P(C,V)9*C16	HD48	1.03	1.01	0.93
P(C,V)9*C20	HD48	1.03	1.01	0.93
PV8*A12	UC30A	0.99	0.98	0.94
PV8*B16	UC30B	1.01	1.01	0.93
PV9*A12	UC30A	0.99	0.98	0.95
P(C,V)9*B12	UC30B	1.00	0.98	0.93

COOLING PERFORMANCE DATA																
AIR CONDITIONER MODEL NO.		YCJF36S41S1														
INDOOR COIL MODEL NO.		FC/MC/PC43														
CONDENSING ENTERING AIR TEMPERATURE	IDCFM	1000					1200					1400				
	ID DB (°F)	80	80	75	80	80	80	80	75	80	80	80	80	75	80	80
	ID WB (°F)	57	62	62	67	72	57	62	62	67	72	57	62	62	67	72
65	T.C.	32.5	34.9	34.7	37.5	40.6	34.2	35.8	35.7	38.4	41.8	35.8	36.8	36.7	39.3	43.0
	S.C.	25.5	25.5	24.9	24.8	20.9	25.5	25.5	25.2	25.2	21.7	25.5	25.5	25.5	25.5	22.4
	KW	1.6	1.6	1.6	1.6	1.6	1.6	1.6	1.6	1.6	1.6	1.6	1.6	1.6	1.6	1.6
75	T.C.	31.6	33.6	33.4	36.3	39.1	33.2	34.5	34.3	37.1	40.2	34.8	35.3	35.3	38.0	41.3
	S.C.	25.5	25.5	24.2	24.2	20.2	25.5	25.5	24.9	24.9	21.0	25.5	25.5	25.5	25.5	21.8
	KW	1.8	1.9	1.9	1.9	1.9	1.8	1.9	1.9	1.9	1.9	1.9	1.9	1.9	1.9	1.9
85	T.C.	30.7	32.3	32.1	35.0	37.7	32.2	33.1	33.0	35.9	38.7	33.7	33.9	33.8	36.7	39.6
	S.C.	25.5	25.5	23.6	23.6	19.4	25.5	25.5	24.6	24.6	20.3	25.5	25.5	25.5	25.5	21.3
	KW	2.1	2.1	2.1	2.1	2.1	2.1	2.1	2.1	2.1	2.1	2.1	2.1	2.1	2.1	2.1
95	T.C.	29.7	31.0	30.8	33.7	36.2	31.2	31.7	31.6	34.6	37.1	32.6	32.5	32.4	35.4	37.9
	S.C.	25.5	25.5	22.9	23.0	18.7	25.5	25.5	24.2	24.3	19.7	25.5	25.5	25.5	25.5	20.7
	KW	2.3	2.3	2.3	2.4	2.4	2.3	2.3	2.4	2.4	2.4	2.3	2.3	2.4	2.4	2.4
105	T.C.	28.3	29.3	29.0	31.9	34.2	29.7	30.0	29.7	32.7	35.0	31.0	30.7	30.4	33.4	35.8
	S.C.	25.5	25.2	22.0	22.1	17.9	25.5	25.4	23.3	23.4	18.7	25.5	25.5	24.7	24.7	19.6
	KW	2.7	2.7	2.8	2.8	2.8	2.7	2.7	2.8	2.8	2.8	2.7	2.7	2.8	2.8	2.8
115	T.C.	26.9	27.7	27.3	30.1	32.1	28.2	28.3	27.9	30.8	32.9	29.4	29.0	28.5	31.4	33.6
	S.C.	25.5	24.9	21.1	21.3	17.1	25.5	25.2	22.4	22.6	17.8	25.5	25.5	23.8	23.9	18.5
	KW	3.1	3.1	3.2	3.1	3.3	3.1	3.1	3.2	3.1	3.3	3.1	3.1	3.3	3.1	3.3
125	T.C.	25.5	26.0	25.5	28.3	30.1	26.7	26.6	26.0	28.9	30.8	27.8	27.2	26.5	29.5	31.4
	S.C.	25.5	24.5	20.1	20.4	16.2	25.5	25.0	21.5	21.7	16.8	25.5	25.5	22.9	23.1	17.4
	KW	3.5	3.5	3.6	3.5	3.8	3.5	3.5	3.7	3.5	3.8	3.5	3.4	3.8	3.5	3.7

NOTE: ALL CAPACITIES INCLUDE INDOOR FAN HEAT AT 1250 BTUH/1000 CFM.

Multipliers for determining the performance with other indoor sections.

NOTE: For dry bulb temperatures different than those listed (between 73-87 F), sensible capacity increases by 1060 BTUH per 1000 CFM per degree above the listed temperature and decreases by 1060 BTUH per 1000 CFM per degree below the listed temperature.

Air Handler	Coil	T.C.	S.C.	KW
-	FC/MC/PC35	0.98	0.98	1.00
-	FC/MC/PC36	0.97	0.96	1.00
-	FC/MC/PC37	1.00	1.00	1.00
-	FC/MC/PC48	1.01	1.01	1.00
-	FC/MC/PC60	1.01	1.02	1.00
-	FC/MC62	1.01	1.02	1.00
-	UC60	0.96	0.95	1.00
-	HC36	0.98	0.98	1.00
-	HC42	1.00	1.00	1.00
-	HD48	1.00	1.00	1.00
AHP36	-	1.00	1.01	0.97
AV36	-	1.03	1.05	0.94
AV/SV48	-	0.98	0.98	0.93
F4FP036	-	0.97	0.97	1.00
F4FP040	-	0.97	0.96	1.00
F4FP042	-	0.97	0.96	1.00
F4FV060	-	0.98	0.98	0.92
F5FP048	-	1.03	1.05	0.93
F5FP060	-	0.99	1.00	0.93
MA12B	FC/MC35B	0.98	0.98	1.00
MV12B	FC/MC35B	0.99	0.99	0.95
MV16C	FC/MC35C	1.00	1.00	0.93
MA12B	FC/MC36B	0.97	0.96	1.00
MV12B	FC/MC36B	0.99	0.98	0.95
MV16C	FC/MC36C	0.99	0.98	0.93
MA12B	FC/MC43B	1.00	1.00	1.00
MV12B	FC/MC43B	1.01	1.01	0.95
MV16C	FC/MC43C	1.02	1.02	0.93
MA14D	FC/MC48D	1.01	1.01	1.00
MV12D	FC/MC48D	1.02	1.01	0.93
MV16C	FC/MC48C	1.03	1.03	0.92
MV20D	FC/MC48D	1.03	1.03	0.92
MA14D	FC/MC60D	1.01	1.02	1.00
MV12D	FC/MC60D	1.02	1.02	0.92
MV20D	FC/MC60D	1.03	1.04	0.92
MA14D	FC/MC62D	1.01	1.02	1.00
MV12D	FC/MC62D	1.02	1.02	0.92
MV20D	FC/MC62D	1.04	1.04	0.92

Variable Speed Furnace	Coil	T.C.	S.C.	KW
PV8*B16	FC/MC/PC35B	0.99	0.99	0.95
PV8*C16	FC/MC/PC35C	0.99	0.99	0.94
PV8*C20	FC/MC/PC35C	1.00	1.00	0.94
P(C,V)9*B12	FC/MC/PC35B	0.99	0.99	0.97
P(C,V)9*C16	FC/MC/PC35C	0.99	0.99	0.94
P(C,V)9*C20	FC/MC/PC35C	0.99	0.99	0.95
PV8*A12	FC/MC/PC36A	0.98	0.97	0.97
PV8*B16	FC/MC/PC36B	0.99	0.98	0.95
PV8*C16	FC/MC/PC36C	0.99	0.98	0.94
PV8*C20	FC/MC/PC36C	0.99	0.98	0.94
PV9*A12	FC/MC/PC36A	0.98	0.97	0.99
P(C,V)9*B12	FC/MC/PC36B	0.98	0.97	0.96
P(C,V)9*C16	FC/MC/PC36C	0.99	0.98	0.94
P(C,V)9*C20	FC/MC/PC36C	0.99	0.98	0.95
PV8*A12	FC/MC/PC37A	1.00	1.00	0.98
PV9*A12	FC/MC/PC37A	0.99	0.97	0.97
PV8*B16	FC/MC/PC43B	1.01	1.01	0.95
PV8*C16	FC/MC/PC43C	1.02	1.02	0.94
PV8*C20	FC/MC/PC43C	1.02	1.02	0.93
P(C,V)9*B12	FC/MC/PC43B	1.01	1.01	0.97
P(C,V)9*C16	FC/MC/PC43C	1.02	1.02	0.94
P(C,V)9*C20	FC/MC/PC43C	1.01	1.01	0.95
PV8*C16	FC/MC/PC48C	1.03	1.03	0.93
PV8*C20	FC/MC/PC48C	1.03	1.03	0.93
P(C,V)9*C16	FC/MC/PC48C	1.02	1.03	0.94
P(C,V)9*C20	FC/MC/PC48C	1.02	1.03	0.94
P(C,V)9*D20	FC/MC/PC48D	1.02	1.03	0.94
PV8*B16	HC36B	0.99	0.99	0.95
P(C,V)9*B12	HC36B	0.99	0.99	0.96
PV8*C16	HC42C	1.02	1.02	0.94
PV8*C20	HC42C	1.02	1.02	0.93
P(C,V)9*C16	HC42C	1.02	1.02	0.94
P(C,V)9*C20	HC42C	1.01	1.01	0.95
PV8*C16	HD48	1.02	1.02	0.93
PV8*C20	HD48	1.02	1.02	0.93
P(C,V)9*C16	HD48	1.02	1.01	0.94
P(C,V)9*C20	HD48	1.02	1.01	0.94
P(C,V)9*D20	HD48	1.02	1.01	0.94
PV8*C20	FC/MC62D	1.03	1.04	0.93
P(C,V)9*C16	FC/MC62D	1.03	1.03	0.94
P(C,V)9*C20	FC/MC62D	1.03	1.03	0.94
P(C,V)9*D20	FC/MC62D	1.03	1.03	0.94
PV8*C16	UC60C	0.98	0.96	0.93
PV8*C20	UC60C	0.98	0.97	0.93
P(C,V)9*C16	UC60C	0.98	0.96	0.94
P(C,V)9*C20	UC60C	0.98	0.96	0.94
P(C,V)9*D20	UC60D	0.98	0.96	0.94

COOLING PERFORMANCE DATA																
AIR CONDITIONER MODEL NO.		YCJF42S41S1														
INDOOR COIL MODEL NO.		FC/MC/PC48														
CONDENSING ENTERING AIR TEMPERATURE	IDCFM	1200					1400					1600				
	ID DB (°F)	80	80	75	80	80	80	80	75	80	80	80	80	75	80	80
	ID WB (°F)	57	62	62	67	72	57	62	62	67	72	57	62	62	67	72
65	T.C.	40.7	42.7	42.3	45.8	48.7	42.2	43.5	43.1	46.7	49.6	43.8	44.3	43.9	47.5	50.5
	S.C.	39.9	36.7	30.9	30.4	23.9	41.5	39.4	33.0	32.5	25.0	43.2	42.0	35.1	34.7	26.1
	KW	1.9	1.9	1.9	1.9	1.9	1.9	1.9	1.9	1.9	1.9	1.9	1.9	1.9	1.9	1.9
75	T.C.	39.3	40.8	40.7	43.9	47.3	40.8	41.7	41.4	44.8	48.0	42.3	42.5	42.2	45.7	48.8
	S.C.	38.4	35.6	30.1	29.6	23.2	40.0	38.3	32.2	31.8	24.4	41.7	40.9	34.4	34.1	25.6
	KW	2.2	2.2	2.2	2.2	2.2	2.2	2.2	2.2	2.2	2.2	2.2	2.2	2.2	2.2	2.2
85	T.C.	37.9	38.9	39.1	42.1	45.9	39.3	39.9	39.8	42.9	46.5	40.8	40.8	40.5	43.8	47.0
	S.C.	36.8	34.6	29.2	28.9	22.6	38.5	37.2	31.4	31.2	23.9	40.2	39.8	33.7	33.4	25.2
	KW	2.5	2.5	2.5	2.5	2.5	2.5	2.5	2.5	2.5	2.5	2.5	2.5	2.5	2.5	2.5
95	T.C.	36.5	37.0	37.5	40.3	44.5	37.9	38.0	38.2	41.1	44.9	39.3	39.1	38.8	41.9	45.3
	S.C.	35.3	33.5	28.3	28.1	21.9	37.0	36.1	30.6	30.5	23.3	38.7	38.7	33.0	32.8	24.7
	KW	2.8	2.8	2.8	2.8	2.8	2.8	2.8	2.8	2.8	2.8	2.8	2.8	2.8	2.8	2.8
105	T.C.	34.7	34.9	35.1	37.8	41.8	36.0	36.0	35.8	38.6	42.2	37.2	37.1	36.4	39.4	42.7
	S.C.	33.4	32.4	27.3	27.2	21.1	35.0	34.7	29.6	29.5	22.5	36.6	36.9	31.8	31.8	23.8
	KW	3.3	3.3	3.3	3.3	3.2	3.3	3.3	3.3	3.3	3.2	3.3	3.3	3.3	3.3	3.2
115	T.C.	32.9	32.9	32.9	35.4	39.2	34.1	34.0	33.5	36.1	39.7	35.3	35.1	34.1	36.9	40.1
	S.C.	31.7	31.3	26.4	26.3	20.3	33.1	33.2	28.5	28.6	21.7	34.6	35.2	30.6	30.8	23.0
	KW	3.8	3.8	3.8	3.7	3.7	3.8	3.8	3.8	3.7	3.7	3.7	3.7	3.8	3.7	3.7
125	T.C.	31.1	30.8	30.6	33.0	36.6	32.2	32.0	31.2	33.7	37.1	33.3	33.1	31.8	34.4	37.6
	S.C.	29.9	30.2	25.5	25.4	19.5	31.3	31.8	27.5	27.7	20.8	32.6	33.4	29.5	29.9	22.1
	KW	4.3	4.3	4.3	4.2	4.1	4.3	4.2	4.3	4.1	4.1	4.2	4.2	4.3	4.1	4.1

NOTE: ALL CAPACITIES INCLUDE INDOOR FAN HEAT AT 1250 BTUH/1000 CFM.

Multipliers for determining the performance with other indoor sections.

NOTE: For dry bulb temperatures different than those listed (between 73-87 F), sensible capacity increases by 1060 BTUH per 1000 CFM per degree above the listed temperature and decreases by 1060 BTUH per 1000 CFM per degree below the listed temperature.

Air Handler	Coil	T.C.	S.C.	KW
-	FC/MC/PC42	0.94	0.93	1.00
-	FC/MC/PC43	0.99	0.99	1.00
-	FC/MC/PC60	1.00	1.00	1.00
-	FC/MC62	1.00	1.00	1.00
-	HC42	0.99	0.99	1.00
-	HD48	1.00	0.98	1.00
-	HD60	1.01	1.01	1.00
AV/SV48	-	0.97	0.95	0.94
AV/SV60	-	0.97	0.95	0.94
F4FV060	-	0.97	0.96	0.93
F5FP048	-	1.02	1.04	0.95
F5FP060	-	0.97	0.97	0.95
MA16C	FC/MC43C	0.99	0.99	1.00
MV16C	FC/MC43C	1.00	1.00	0.95
MA14D	FC/MC48D	1.00	1.00	1.00
MA16C	FC/MC48C	1.00	1.00	1.00
MV16C	FC/MC48C	1.02	1.02	0.95
MV20D	FC/MC48D	1.02	1.02	0.94
MA14D	FC/MC60D	1.00	1.00	1.00
MA16C	FC/MC60C	1.00	1.00	1.00
MV20D	FC/MC60D	1.01	1.02	0.93
MA14D	FC/MC62D	1.00	1.00	1.00
MV20D	FC/MC62D	1.02	1.02	0.93

Variable Speed Furnace	Coil	T.C.	S.C.	KW
PV8*B16	FC/MC/PC43B	1.00	0.99	0.97
PV8*C20	FC/MC/PC43C	1.00	1.00	0.96
P(C,V)9*C16	FC/MC/PC43C	1.00	0.99	0.98
P(C,V)9*C20	FC/MC/PC43C	1.00	1.00	0.96

Variable Speed Furnace	Coil	T.C.	S.C.	KW
PV8*C16	FC/MC/PC48C	1.01	1.01	0.97
PV8*C20	FC/MC/PC48C	1.01	1.01	0.96
P(C,V)9*C16	FC/MC/PC48C	1.01	1.01	0.98
P(C,V)9*C20	FC/MC/PC48C	1.01	1.01	0.96
P(C,V)9*D20	FC/MC/PC48D	1.01	1.01	0.95
PV8*C16	FC/MC/PC60C	1.01	1.01	0.96
PV8*C20	FC/MC/PC60C	1.01	1.01	0.96
P(C,V)9*C16	FC/MC/PC60C	1.00	1.01	0.97
P(C,V)9*C20	FC/MC/PC60C	1.01	1.01	0.96
P(C,V)9*D20	FC/MC/PC60D	1.01	1.02	0.95
PV8*C16	HC42C	1.00	1.00	0.97
PV8*C20	HC42C	1.00	1.00	0.96
P(C,V)9*C16	HC42C	1.00	0.99	0.98
P(C,V)9*C20	HC42C	1.00	1.00	0.96
P(C,V)9*D20	HC60D	0.96	0.95	0.94
PV8*C16	HD48	1.01	1.00	0.96
PV8*C20	HD48	1.01	1.00	0.96
P(C,V)9*C16	HD48	1.00	0.99	0.98
P(C,V)9*C20	HD48	1.01	1.00	0.96
P(C,V)9*D20	HD48	1.01	1.00	0.95
PV8*C16	HD60	1.02	1.02	0.96
PV8*C20	HD60	1.02	1.02	0.96
P(C,V)9*C16	HD60	1.02	1.02	0.97
P(C,V)9*C20	HD60	1.02	1.02	0.96
P(C,V)9*D20	HD60	1.03	1.03	0.95
PV8*C20	FC/MC62D	1.01	1.02	0.96
P(C,V)9*C16	FC/MC62D	1.01	1.01	0.97
P(C,V)9*C20	FC/MC62D	1.01	1.01	0.96
P(C,V)9*D20	FC/MC62D	1.02	1.02	0.95

COOLING PERFORMANCE DATA																
AIR CONDITIONER MODEL NO.		YCJF48S41S1														
INDOOR COIL MODEL NO.		FC/MC/PC60														
CONDENSING ENTERING AIR TEMPERATURE	IDCFM	1400					1600					1800				
	ID DB (°F)	80	80	75	80	80	80	80	75	80	80	80	80	75	80	80
	ID WB (°F)	57	62	62	67	72	57	62	62	67	72	57	62	62	67	72
65	T.C.	44.1	45.2	43.0	47.2	47.3	44.2	45.3	43.9	47.4	47.9	44.2	45.3	44.8	47.6	48.5
	S.C.	43.7	39.0	33.0	31.2	24.2	44.3	40.6	34.5	32.2	24.8	44.9	42.3	36.0	33.2	25.5
	KW	2.2	2.2	2.2	2.2	2.2	2.2	2.2	2.2	2.2	2.3	2.2	2.2	2.2	2.2	2.3
75	T.C.	42.6	43.5	41.7	45.7	46.9	43.0	43.8	42.5	46.1	47.5	43.5	44.1	43.2	46.5	48.2
	S.C.	42.4	39.0	33.0	31.3	24.3	43.3	40.8	34.6	32.6	25.0	44.1	42.6	36.3	33.9	25.7
	KW	2.5	2.5	2.5	2.5	2.6	2.5	2.5	2.5	2.5	2.6	2.5	2.5	2.5	2.5	2.6
85	T.C.	41.0	41.9	40.4	44.1	46.5	41.9	42.4	41.0	44.8	47.2	42.7	42.9	41.6	45.4	47.9
	S.C.	41.1	38.9	32.9	31.4	24.3	42.2	40.9	34.7	33.0	25.2	43.4	42.9	36.6	34.6	26.0
	KW	2.8	2.8	2.8	2.9	2.9	2.8	2.8	2.8	2.9	2.9	2.8	2.8	2.8	2.9	2.9
95	T.C.	39.5	40.2	39.1	42.6	46.0	40.7	41.0	39.5	43.5	46.8	42.0	41.8	40.0	44.3	47.6
	S.C.	39.8	38.9	32.8	31.5	24.4	41.2	41.1	34.8	33.4	25.3	42.6	43.2	36.9	35.2	26.3
	KW	3.1	3.2	3.1	3.2	3.2	3.1	3.2	3.1	3.2	3.2	3.1	3.2	3.1	3.2	3.2
105	T.C.	37.1	37.6	36.0	39.8	43.4	38.3	38.6	36.6	40.6	44.1	39.5	39.6	37.2	41.4	44.8
	S.C.	37.3	36.8	31.4	30.5	23.5	38.6	38.7	33.5	32.5	24.6	40.0	40.5	35.5	34.4	25.7
	KW	3.6	3.6	3.6	3.6	3.7	3.6	3.6	3.6	3.6	3.7	3.6	3.6	3.6	3.6	3.7
115	T.C.	34.9	35.0	33.0	37.1	40.8	36.0	36.3	33.7	37.8	41.5	37.1	37.5	34.4	38.5	42.1
	S.C.	34.8	34.8	30.0	29.5	22.7	36.2	36.4	32.1	31.6	24.0	37.5	37.9	34.2	33.6	25.2
	KW	4.0	4.0	4.0	4.0	4.1	4.0	4.0	4.0	4.0	4.1	4.0	4.0	4.0	4.1	4.1
125	T.C.	32.6	32.5	30.1	34.4	38.2	33.6	33.9	30.8	35.0	38.8	34.6	35.4	31.6	35.7	39.5
	S.C.	32.4	32.9	28.7	28.4	21.9	33.7	34.1	30.8	30.6	23.3	34.9	35.3	32.9	32.9	24.6
	KW	4.4	4.4	4.4	4.5	4.6	4.4	4.4	4.4	4.5	4.6	4.5	4.5	4.4	4.5	4.6

NOTE: ALL CAPACITIES INCLUDE INDOOR FAN HEAT AT 1250 BTUH/1000 CFM.

Multipliers for determining the performance with other indoor sections.

NOTE: For dry bulb temperatures different than those listed (between 73-87 F), sensible capacity increases by 1060 BTUH per 1000 CFM per degree above the listed temperature and decreases by 1060 BTUH per 1000 CFM per degree below the listed temperature.

Air Handler	Coil	T.C.	S.C.	KW
-	FC/MC/PC48	1.00	1.00	1.00
-	FC/MC62	1.01	1.00	1.00
-	HD48	1.00	1.00	1.00
-	HD60	1.02	1.02	1.00
AHP/SHP60	-	0.95	0.94	0.97
AV/SV48	-	0.95	0.94	0.96
AV/SV60	-	0.95	0.94	0.96
F4FV060	-	0.95	0.94	0.96
F5FP048	-	1.01	1.04	0.97
F5FP060	-	0.95	0.95	0.98
MA16C	FC/MC48C	1.00	1.00	1.00
MA20D	FC/MC48D	1.00	1.00	1.00
MV16C	FC/MC48C	1.01	1.01	0.96
MV20D	FC/MC48D	1.01	1.01	0.96
MA16C	FC/MC60C	1.00	1.00	1.00
MA20D	FC/MC60D	1.00	1.00	1.00
MV20D	FC/MC60D	1.01	1.01	0.96
MA20D	FC/MC62D	1.01	1.00	1.00
MV20D	FC/MC62D	1.02	1.01	0.96

Variable Speed Furnace	Coil	T.C.	S.C.	KW
PV8*C16	FC/MC/PC48C	0.99	0.97	0.98
PV8*C20	FC/MC/PC48C	1.00	1.00	0.99
P(C,V)9*C16	FC/MC/PC48C	1.00	1.00	1.00
P(C,V)9*C20	FC/MC/PC48C	1.00	1.01	0.98
PV8*C16	FC/MC/PC60C	0.99	0.98	0.98
PV8*C20	FC/MC/PC60C	1.01	1.01	0.98
P(C,V)9*C16	FC/MC/PC60C	1.00	1.00	1.00
P(C,V)9*C20	FC/MC/PC60C	1.00	1.00	0.98
P(C,V)9*D20	FC/MC/PC60D	1.01	1.01	0.97
PV8*C16	HD48	0.99	0.97	0.98
PV8*C20	HD48	1.00	1.00	0.98
P(C,V)9*C16	HD48	1.00	1.00	1.00
P(C,V)9*C20	HD48	1.00	1.00	0.98
P(C,V)9*D20	HD48	1.01	1.00	0.97
PV8*C16	HD60	1.01	0.99	0.98
PV8*C20	HD60	1.02	1.02	0.98
P(C,V)9*C16	HD60	1.02	1.02	1.00
P(C,V)9*C20	HD60	1.02	1.02	0.98
P(C,V)9*D20	HD60	1.02	1.03	0.97
PV8*C20	FC/MC62D	1.01	1.01	0.98
P(C,V)9*C16	FC/MC62D	1.01	1.00	1.00
P(C,V)9*C20	FC/MC62D	1.01	1.01	0.98
P(C,V)9*D20	FC/MC62D	1.01	1.01	0.97

COOLING PERFORMANCE DATA																
AIR CONDITIONER MODEL NO.		YCJF60S41S1														
INDOOR COIL MODEL NO.		FC/MC/PC62														
CONDENSING ENTERING AIR TEMPERATURE	IDCFM	1400					1600					1800				
	ID DB (°F)	80	80	75	80	80	80	80	75	80	80	80	80	75	80	80
	ID WB (°F)	57	62	62	67	72	57	62	62	67	72	57	62	62	67	72
65	T.C.	54.5	57.8	56.7	62.8	68.7	55.3	59.1	58.5	64.7	69.7	56.1	60.4	60.2	66.6	70.7
	S.C.	54.0	49.2	40.9	40.7	32.5	56.2	52.4	43.1	42.9	34.1	58.5	55.7	45.3	45.1	35.8
	KW	2.7	2.7	2.6	2.7	2.6	2.7	2.7	2.7	2.7	2.7	2.7	2.7	2.7	2.7	2.7
75	T.C.	52.7	55.6	54.4	60.5	66.0	54.8	56.8	56.1	62.1	66.9	56.9	58.0	57.7	63.7	67.9
	S.C.	52.3	48.1	39.9	39.8	31.5	54.3	51.1	42.2	41.9	33.1	56.4	54.2	44.4	44.1	34.7
	KW	3.1	3.1	3.1	3.1	3.1	3.1	3.1	3.1	3.1	3.1	3.1	3.1	3.1	3.1	3.1
85	T.C.	50.8	53.5	52.2	58.1	63.3	54.3	54.5	53.7	59.5	64.2	57.7	55.6	55.2	60.8	65.1
	S.C.	50.6	47.1	38.9	38.9	30.5	52.4	49.9	41.2	41.0	32.1	54.3	52.7	43.6	43.0	33.6
	KW	3.5	3.6	3.5	3.5	3.5	3.5	3.6	3.5	3.5	3.5	3.5	3.6	3.5	3.5	3.5
95	T.C.	49.0	51.4	50.0	55.8	60.5	53.7	52.3	51.3	56.8	61.4	58.4	53.2	52.6	57.9	62.3
	S.C.	48.9	46.0	37.9	38.1	29.5	50.5	48.6	40.3	40.0	31.0	52.2	51.2	42.7	41.9	32.6
	KW	4.0	4.0	4.0	4.0	4.0	4.0	4.0	4.0	4.0	4.0	4.0	4.0	4.0	4.0	4.0
105	T.C.	46.4	48.2	46.9	52.5	57.0	50.0	49.3	48.1	53.3	58.0	53.7	50.4	49.3	54.2	59.0
	S.C.	46.5	44.6	36.7	36.5	28.1	48.0	47.0	39.0	38.5	29.6	49.5	49.3	41.2	40.5	31.1
	KW	4.8	4.8	4.8	4.7	4.7	4.8	4.8	4.8	4.7	4.7	4.7	4.8	4.8	4.7	4.7
115	T.C.	43.8	45.2	43.9	49.3	53.6	46.5	46.4	45.0	50.0	54.7	49.1	47.6	46.1	50.7	55.9
	S.C.	44.1	43.3	35.5	35.0	26.8	45.5	45.4	37.6	37.1	28.3	46.9	47.5	39.8	39.2	29.7
	KW	5.6	5.6	5.7	5.4	5.4	5.5	5.5	5.6	5.4	5.3	5.5	5.5	5.5	5.4	5.3
125	T.C.	41.3	42.2	40.8	46.0	50.2	42.9	43.5	41.9	46.6	51.5	44.5	44.9	42.9	47.2	52.7
	S.C.	41.8	41.9	34.3	33.5	25.5	43.1	43.8	36.3	35.7	26.9	44.4	45.6	38.3	37.8	28.3
	KW	6.4	6.4	6.5	6.1	6.0	6.3	6.3	6.4	6.1	6.0	6.2	6.2	6.3	6.1	6.0

NOTE: ALL CAPACITIES INCLUDE INDOOR FAN HEAT AT 1250 BTUH/1000 CFM.

Multipliers for determining the performance with other indoor sections.

NOTE: For dry bulb temperatures different than those listed (between 73-87 F), sensible capacity increases by 1060 BTUH per 1000 CFM per degree above the listed temperature and decreases by 1060 BTUH per 1000 CFM per degree below the listed temperature.

Air Handler	Coil	T.C.	S.C.	KW
-	FC/MC/PC60	0.96	0.98	1.00
-	HC60	0.96	0.98	1.00
AV/SV60	-	0.97	0.99	0.97
MV20D	FC/MC60D	0.97	0.99	0.98
MA20D	FC/MC62D	1.00	1.00	1.00
MV20D	FC/MC62D	1.01	1.01	0.98

Variable Speed Furnace	Coil	T.C.	S.C.	KW
P(C,V)9*D20	HC60D	0.95	0.93	0.97
PV8*C20	HD60	0.99	0.99	0.99
P(C,V)9*C20	HD60	0.99	0.99	0.98
P(C,V)9*D20	HD60	0.98	0.97	0.97
PV8*C20	FC/MC62D	1.00	1.00	0.99
P(C,V)9*C20	FC/MC62D	0.98	0.97	0.98
P(C,V)9*D20	FC/MC62D	0.99	0.96	0.97

NOTES